



ELECTRICAL POWER SHEARS

EPS-1014E EPS-1016E
EPS-1014M EPS-0610M
EPS-0412M EPS-0410M

OPERATION & PARTS MANUALS



1. Structure and Use

The machine tool adopts the type of lower transmission structure, and the small sprocket wheel mounted on the gear reducer drives the big chain wheel directly, thus driving the eccentric wheel on the spindle to do the periodical rotation movement, and the upper and lower reciprocating motion of the upper tool holder can realize the cutting function of the machine tool.

The main structure of the machine tool frame, the upper tool frame and the worktable all adopt the steel plate welding structure, and the protection is the full protection structure, and has the power of power break protection. So the structure of the machine tool is of high strength, beautiful appearance, compact, safe and reliable

Model	EPS-1016E	EPS-1014E	EPS-1014M	EPS-0610M	EPS-0410M	EPS-0412M
Max. cutting capacity Mild steel Stainless steel	16Ga. 20Ga.	14Ga. 18Ga.	14Ga 18Ga	10Ga 14Ga	10Ga 14Ga	12Ga 16Ga
Max. cutting width	10'1"	10'1"	10'1"	6'6"	4'4"	4'4"
Rake angle degree	1.5°	2°	2°	2.5°	2.2°	2°
Upper blade ram max. travel	4"					
cutting stroke	19/min	19/min	19/min	25/min	29/min	29/min
Working Table Height	32-1/2"					
Back Gauge	36"	36"	26"	26"	26"	26"
Main motor, HP	7-1/2HP, 220/440V			7-1/2HP 220/440V	5-1/2HP 220/440V	4HP 220/440V
Motor for powered back gauge	1-1/2HP, 220V/440V					
Machine weight, Lbs Dimensions, LWH	7,150 145x69x63"	7,850 145x69x63"	6,850 145x59x63"	5,650 100x55x60"	4,350 73x55x60"	3,350 72x55x60"

Safety Warnings

1. Read and understand the entire owner's manual before attempting assembly or operation.

2. This machine is designed and intended for use by properly trained and experienced personnel only. If you are not familiar with the proper and safe operation of a shear, do not use until proper training and knowledge have been obtained.

3. Do not use this machine for other than its intended use.

4. Always wear safety glasses/face shields while using this shear.

5. Do not wear loose clothing, gloves, neckties, rings, bracelets, or other jewelry which may get caught in moving parts. Wear protective hair covering to contain long hair. Non-slip footwear or anti-skid floor strips are recommended.

6. Do not operate this machine while tired or under the influence of drugs, alcohol or any medication.

7. Do not exceed the rated capacity of this shear; use hand tools for small or narrow parts. Do not attempt to shear hardened materials.

8. Sheet metal stock has sharp edges. To prevent cuts, use leather work gloves

9. Keep hands and fingers clear of the area in front and rear of the shear.

10. Do not place your hands between material being sheared and the shear table.

11. Keep safety guards in place at all times when the machine is in use. If removed for maintenance purposes, use extreme caution and replace the guards immediately after maintenance is complete.

12. Check damaged parts. Before further use of the machine, a guard or other part that is damaged should be carefully checked to determine that it will operate properly and perform its intended function. Check for alignment of moving parts, binding of moving parts, breakage of parts, mounting and any other conditions that may affect its operation. A guard or other part that is damaged should be properly repaired or replaced.

13. Provide for adequate space surrounding work area and non-glare, overhead lighting.

14. Keep the floor around the machine clean and free of scrap material, oil and grease.

15. Keep visitors a safe distance from the work area. **KEEP CHILDREN AWAY.**

16. Make your workshop child proof with padlocks, master switches or by removing starter keys.

17. Give your work undivided attention. Looking around, carrying on a conversation and “horse-play” are careless acts that can result in serious injury.

18. Maintain a balanced stance at all times so that you do not fall or lean against moving parts. Do not overreach or use excessive force to perform any machine operation.

19. Use the right tool at the correct speed and feed rate. Do not force a tool or attachment to do a job for which it was not designed. The right tool will do job better and more safety.

20. Use recommended accessories; improper accessories may be hazardous.

21. Maintain tools with care. Keep tools sharp and clean for the best and safest performance. Follow instructions for lubricating and changing accessories.

22. Do not stand on the machine. Serious injury could occur if the machine tips over.

23. Unplug or lock out power to the machine when not in use.

24. Check if the transportation procedure has influenced the accuracy and functions of the machine.

25. Check if the foundation of the machine is appropriate.

26. Check if the machine's main power switch should have earth wiring connected.

27. Use the multimeter to check the stability of the three-phase voltage

SECTION 1: SAFETY

For Your Own Safety, Read Instruction Manual Before Operating This Machine

The purpose of safety symbols is to attract your attention to possible hazardous conditions. This manual uses a series of symbols and signal words intended to convey the level of importance of the safety messages. The progression of symbols is described below. Remember that safety messages by themselves do not eliminate danger and are not a substitute for proper accident prevention measures. Always use common sense and good judgment.

⚠ DANGER Indicates an imminently hazardous situation which, if not avoided, WILL result in death or serious injury.

⚠ WARNING Indicates a potentially hazardous situation which, if not avoided, COULD result in death or serious injury.

⚠ CAUTION Indicates a potentially hazardous situation which, if not avoided, MAY result in minor or moderate injury. It may also be used to alert against unsafe practices.

NOTICE This symbol is used to alert the user to useful information about proper operation of the machine.

Safety Instructions for Machinery

⚠ WARNING

OWNER'S MANUAL. Read and understand this owner's manual BEFORE using machine.

TRAINED OPERATORS ONLY. Untrained operators have a higher risk of being hurt or killed. Only allow trained/supervised people to use this machine. When machine is not being used, disconnect power, remove switch keys, or lock-out machine to prevent unauthorized use—especially around children. Make workshop kid proof!

DANGEROUS ENVIRONMENTS. Do not use machinery in areas that are wet, cluttered, or have poor lighting. Operating machinery in these areas greatly increases the risk of accidents and injury.

MENTAL ALERTNESS REQUIRED. Full mental alertness is required for safe operation of machinery. Never operate under the influence of drugs or alcohol, when tired, or when distracted.

ELECTRICAL EQUIPMENT INJURY RISKS. You can be shocked, burned, or killed by touching live electrical components or improperly grounded machinery. To reduce this risk, only allow qualified service personnel to do electrical installation or repair work, and always disconnect power before accessing or exposing electrical equipment.

DISCONNECT POWER FIRST. Always disconnect machine from power supply BEFORE making adjustments, changing tooling, or servicing machine. This prevents an injury risk from unintended startup or contact with live electrical components.

EYE PROTECTION. Always wear ANSI-approved safety glasses or a face shield when operating or observing machinery to reduce the risk of eye injury or blindness from flying particles. Everyday eyeglasses are NOT approved safety glasses.

4.Electrical connection:

A cable with four wires is supplied to connect your machine into the 3 phase power supply. The exact power source voltage, frequency, and number of phase shall be checked according to the installation diagram and circuit diagram. The correct direction of spindle should be checked after connecting

Electrical disconnection:

Be sure to disconnect this machine from power source, when you want to stop the job for maintenance or adjustment.

Grounding

The grounding of this model is carried out by connecting the yellow/green terminal of supply cable to the grounding terminal of power source. Be sure to ground your machine before connecting machine to power source in any situation.

Warning!

Do not disconnect grounding terminal before disconnecting power **source!**

Description for the safety function of this machine

The following safety functions are equipped with this machine. Be sure to check and

ensure the correct function before you start to operate your machine:

The emergency stop device:

The machine is designed to be immediately stopped under emergency situation.

As soon

as this device is actuated, any movement will be stopped in a short time after the actuation of emergency button.

Be sure to check that machine action will stop immediately after this button is pressed and will not cause any action when this button is disengaged.

5. Transportation and Installation

Crane or forklift is recommended

To move the machine, it must slow down, especially pay attention.

The machine is lifted by crane or removed by forklift after the removal of pallet packing.

The length of fork for forklift should be at least 4" over the center of machine.

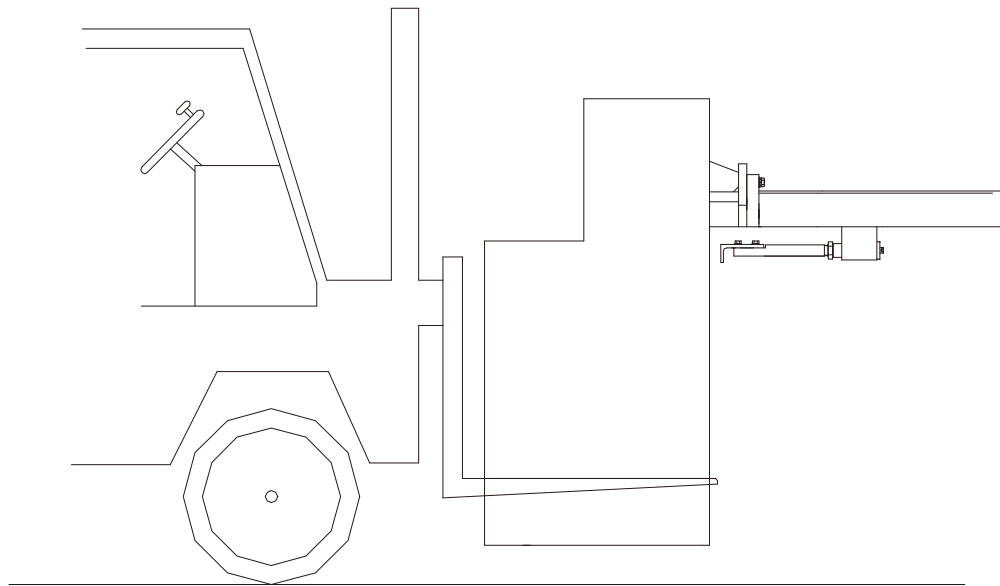

2、 Installation: When installing machine should be installed in a horizontal on the bottom of foundation, adjust the machine table to the horizontal lateral are within 0.3 mm / 1000 mm. According to the fuselage on one side of the machine to four, a total of eight anchor hole, completes the corresponding foundation, through the anchor bolt fix the machine tool based on the level.

Second times grouting First grouting M20

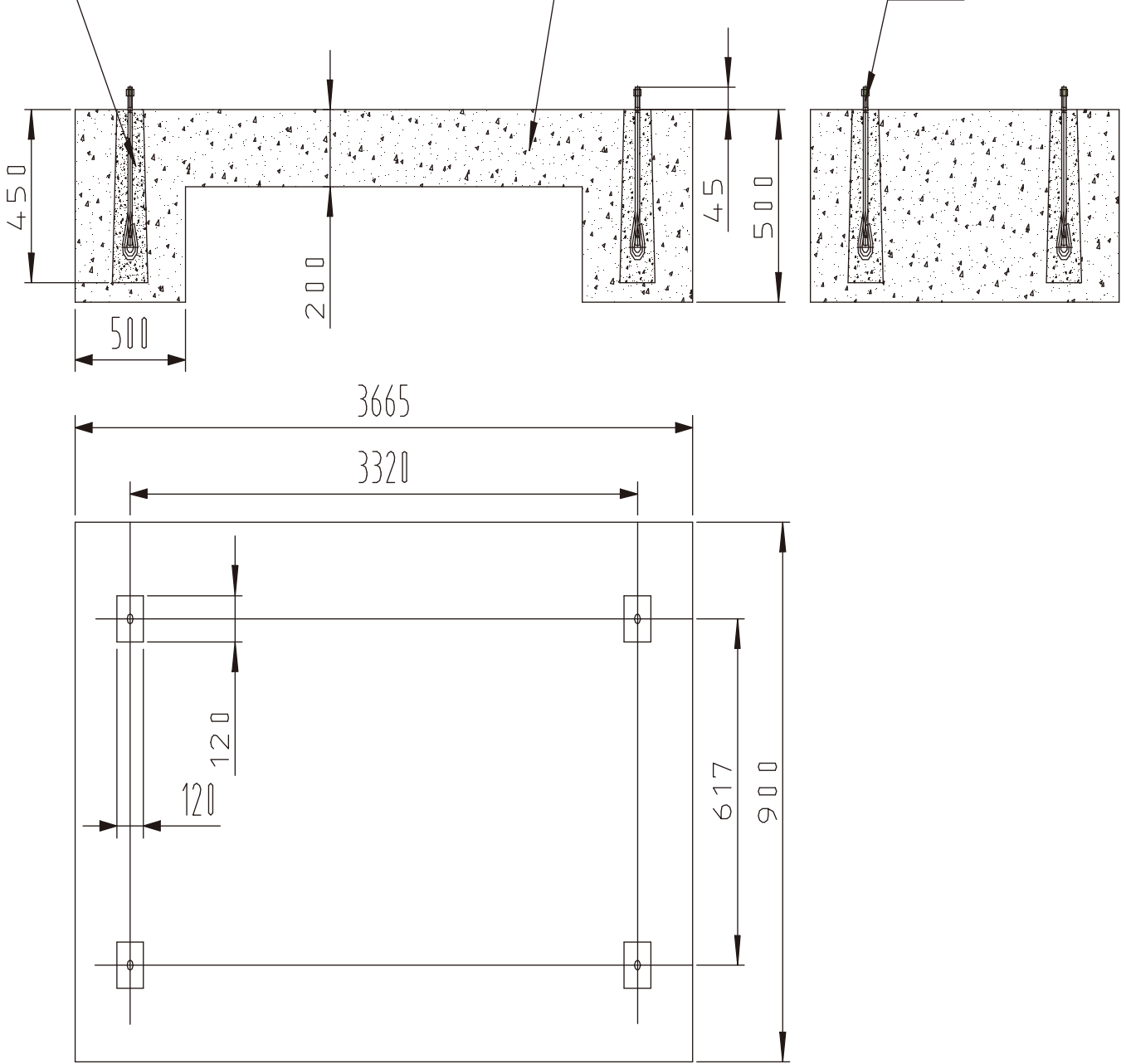

6. Start up

1. Turn on main power switch



2. Toggle selector switch to (S)art.



3. Place selector switch to JOG and press foot pedal to move blade incrementally so blade gap can be checked.



Once blade gap is verified place selector switch in AUTO and press foot pedal, machine should make one complete cycle and blade should stop in the up position (If blade does not stop in the up position or will continually cycle while foot pedal is pressed the phase is incorrect and any two incoming power leads need to be swapped)

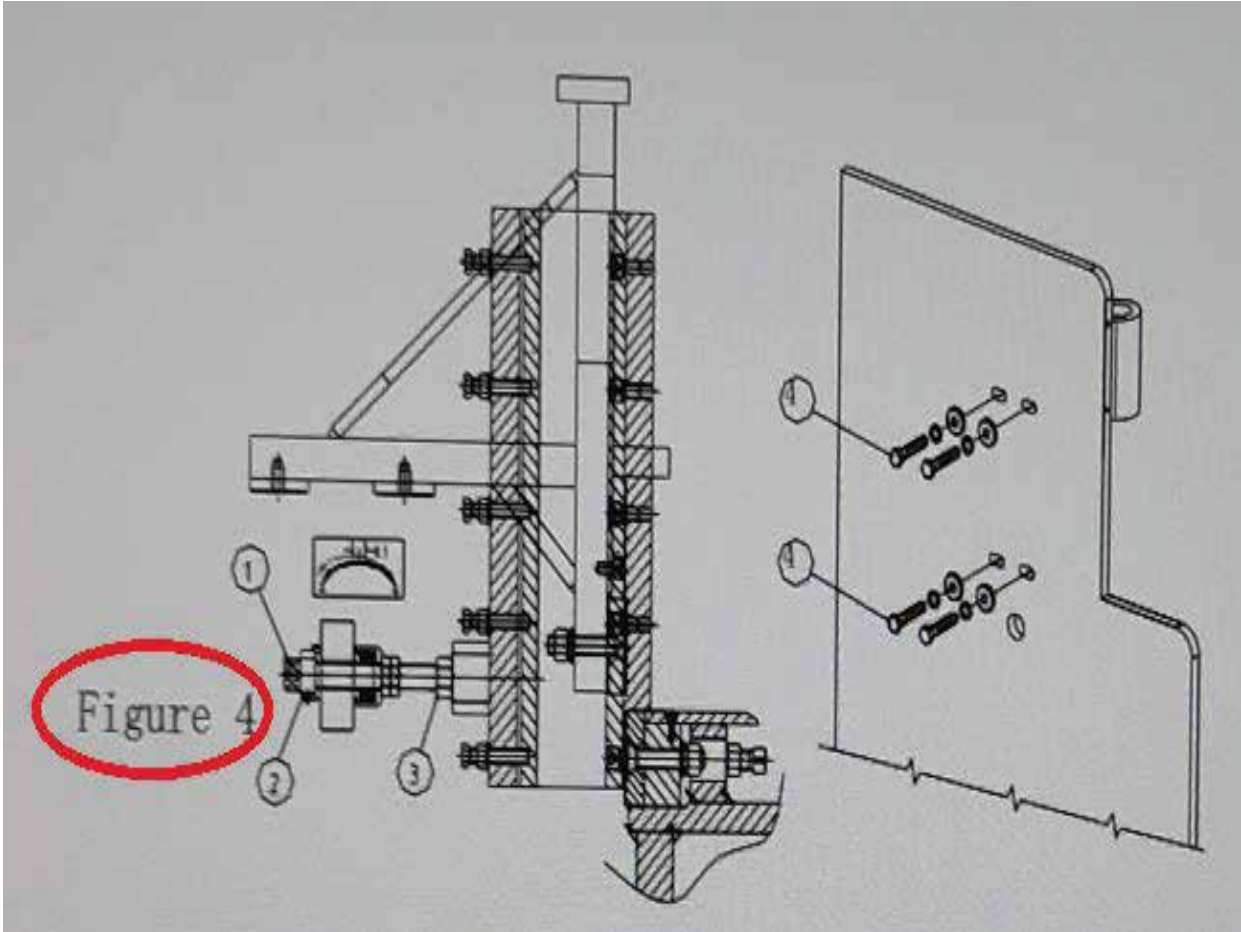

6-1. Machine adjustment

Blade clearance adjustment

Warning extreme care must be taken to avoid bodily injury while checking or adjusting blade gap machine must be in JOG

(The blade clearance is preset for cutting 14Ga. Mild steel

How to adjust blade gap: See figure 4 drawing.

Please loosen locking nuts #3, then loosen all the bolts #4,(both sides of machine) turn screw #1 clockwise to increase the blade clearance, turn screw #1 counterclockwise to reduce the clearance, when the clearance is ok according to feeler gauges, then tighten lock nuts # 3 and Bolts # 4 after recheck blade gap with feeler gauges. 16ga. requires .003”-.005” blade gap
14ga.requires .004”-.006” blade gap.

Blade Clearance Chart

SUGGESTED KNIFE CLEARANCE	
METAL THICKNESS	KNIFE CLEARANCE
16 Gage	.002" - .005"
14 Gage	.003 - .006
12 Gage	.004 - .008
10 Gage	.006 - .009
3/16 inch	.009 - .013
1/4 inch	.010 - .018
3/8 inch	.020 - .028
1/2 inch	.030 - .040
5/8 inch	.040 - .050
3/4 inch	.050 - .065
1 inch	.070 - .090
1-1/4 inch	.090 - .120
1-1/2 inch	.110 - .150

STANDARD SHEET GAGES			
GAGE NO.	THICKNESS INCHES	GAGE NO.	THICKNESS INCHES
30	.0120	16	.0598
29	.0135	15	.0673
28	.0149	14	.0747
27	.0164	13	.0897
26	.0179	12	.1046
25	.0209	11	.1196
24	.0239	10	.1345
23	.0269	9	.1495
22	.0299	8	.1644
21	.0329	7	.1793
20	.0359	6	.1943
19	.0418	5	.2092
18	.0478	4	.2242
17	.0538	3	.2391

SHEARING STRENGTH OF MATERIALS		
MATERIAL	TONS/SQ.IN.	FACTOR
Mild Steel (.25 Carbon)	25	1.00
Mild Steel (.50 Carbon)	30	.83
Stainless Steel	28	.65
Broiler Plate	30	.83
Spring Steel (1.99 Carbon)	42	.60
Tool Steel. Not tempered (1.20 carbon)	45	.56
Tool Steel. tempered (1.20 carbon)	95	.26
Nickel Steel (0.5% Nickel)	41	.61
Aluminum Sheet	10	2.5
Brass	13	1.92
Copper	12.5	2.00
Lead	1.5	16.67
Tin-Coated Sheet Steel	25	1.00
Zinc	8.5	2.94

How to use this table: If the shear is rated 10 Gauge in mild steel, What thickness of stainless steel sheet will it cut?
 $.1345 \times .65 = .075(14Ga)$

6-2. Back gauge movement.

1. Use the FORWARD or REVERSE buttons to rapid travel close to your desired cutting length.



2. then use the hand wheel to fine adjust until the DRO shows your target measurement,



7. Lubrication

When you lubricate the following 1 or 2, please remove the front Plate

.	Lubricate position	quantity	period	Oil type
1	Copper Bush on eccentric wheel	2	Once per shift	Grease, Mobil# Dorcia-150
2	Pin shaft on upper cutting	2	Once per shift	Grease, Mobil# Dorcia-150
3	One shot luber	1	Once per shift	Lubrication oil,Shell Tonna-33

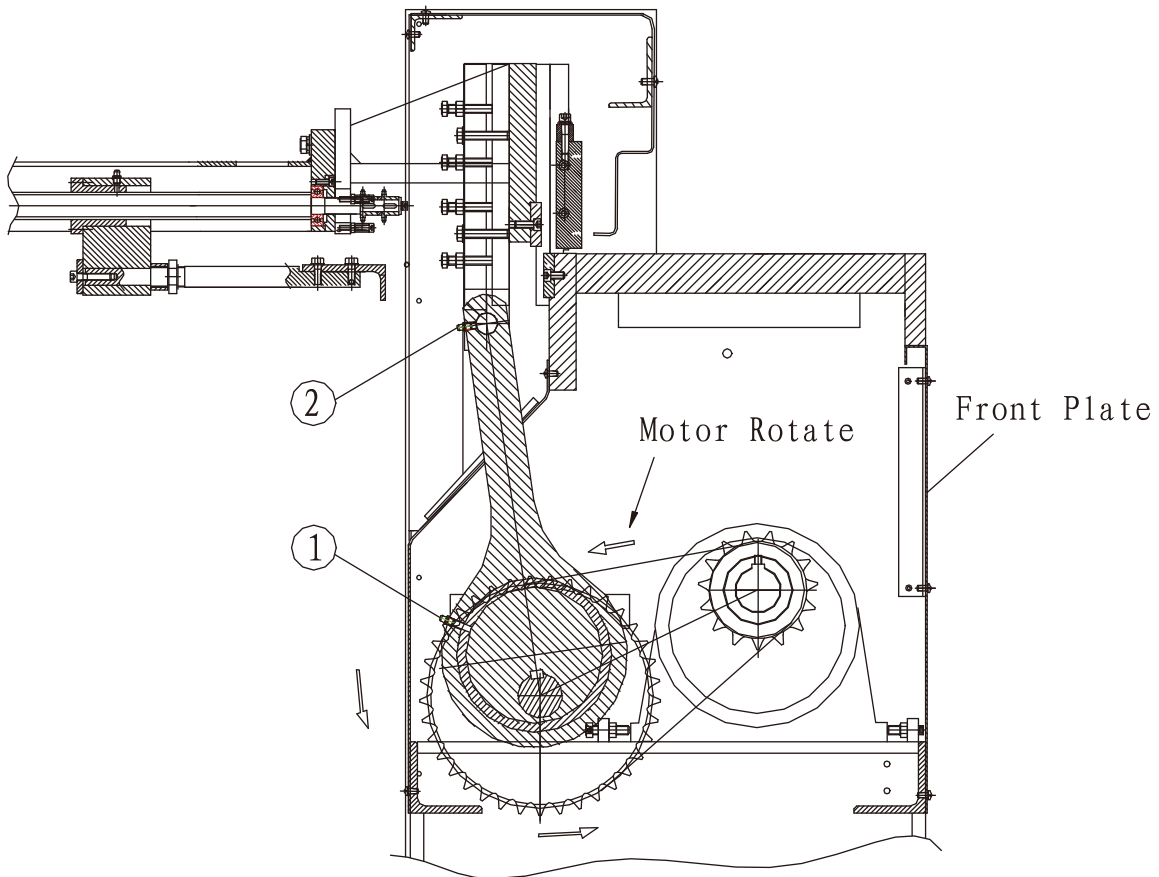

8. Electrical Diagrams

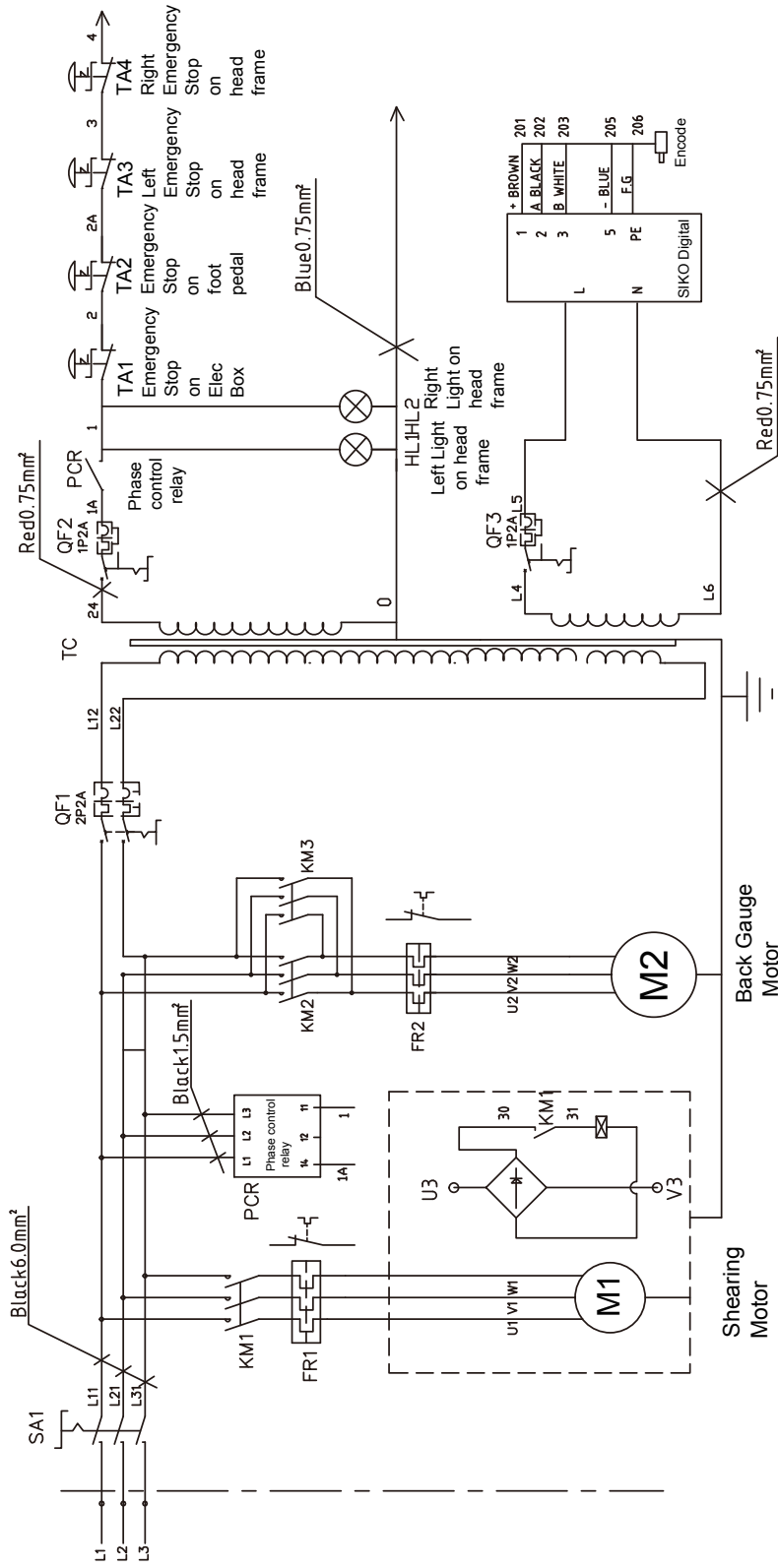

EPS-1014E

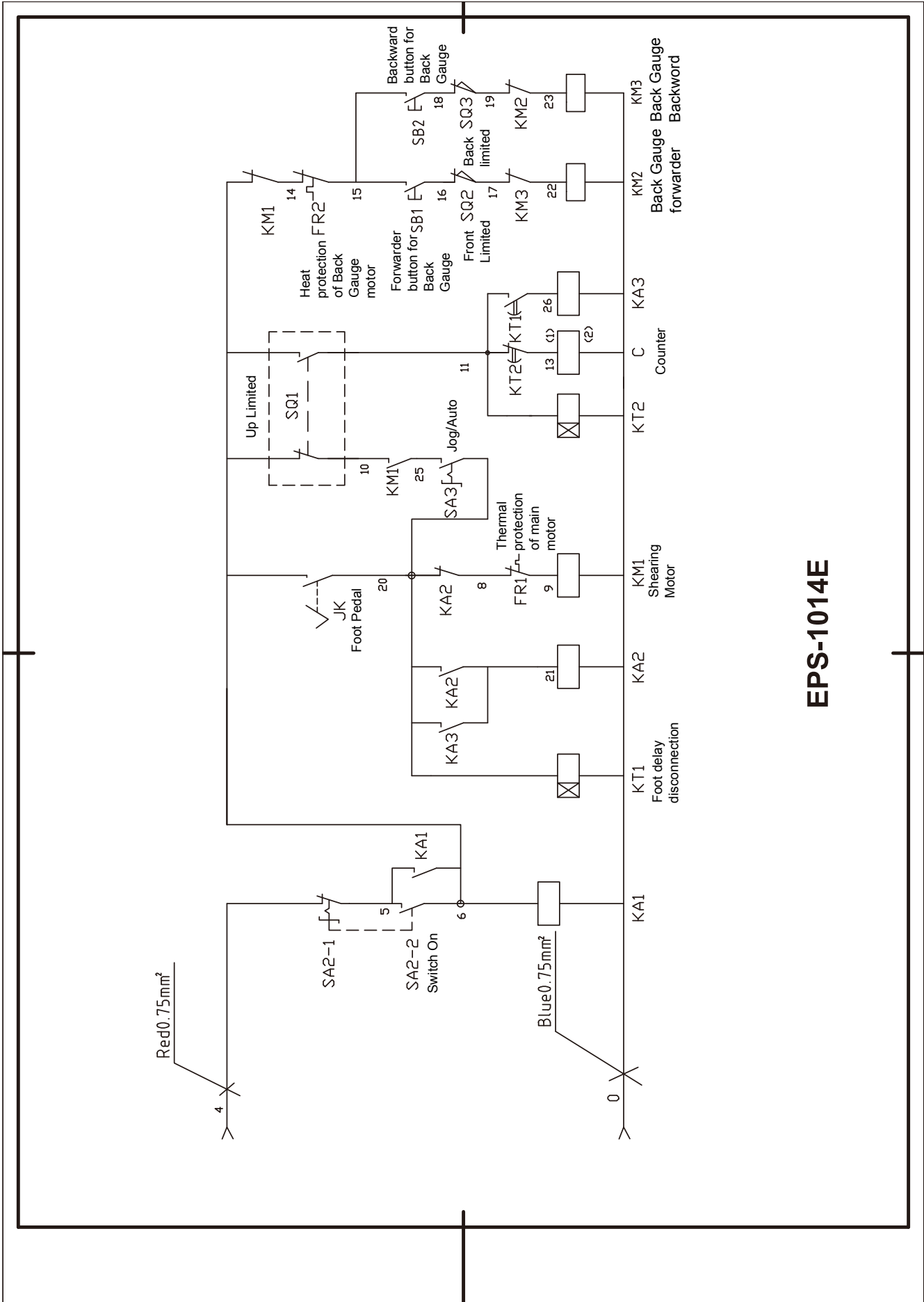

EPS-1014E

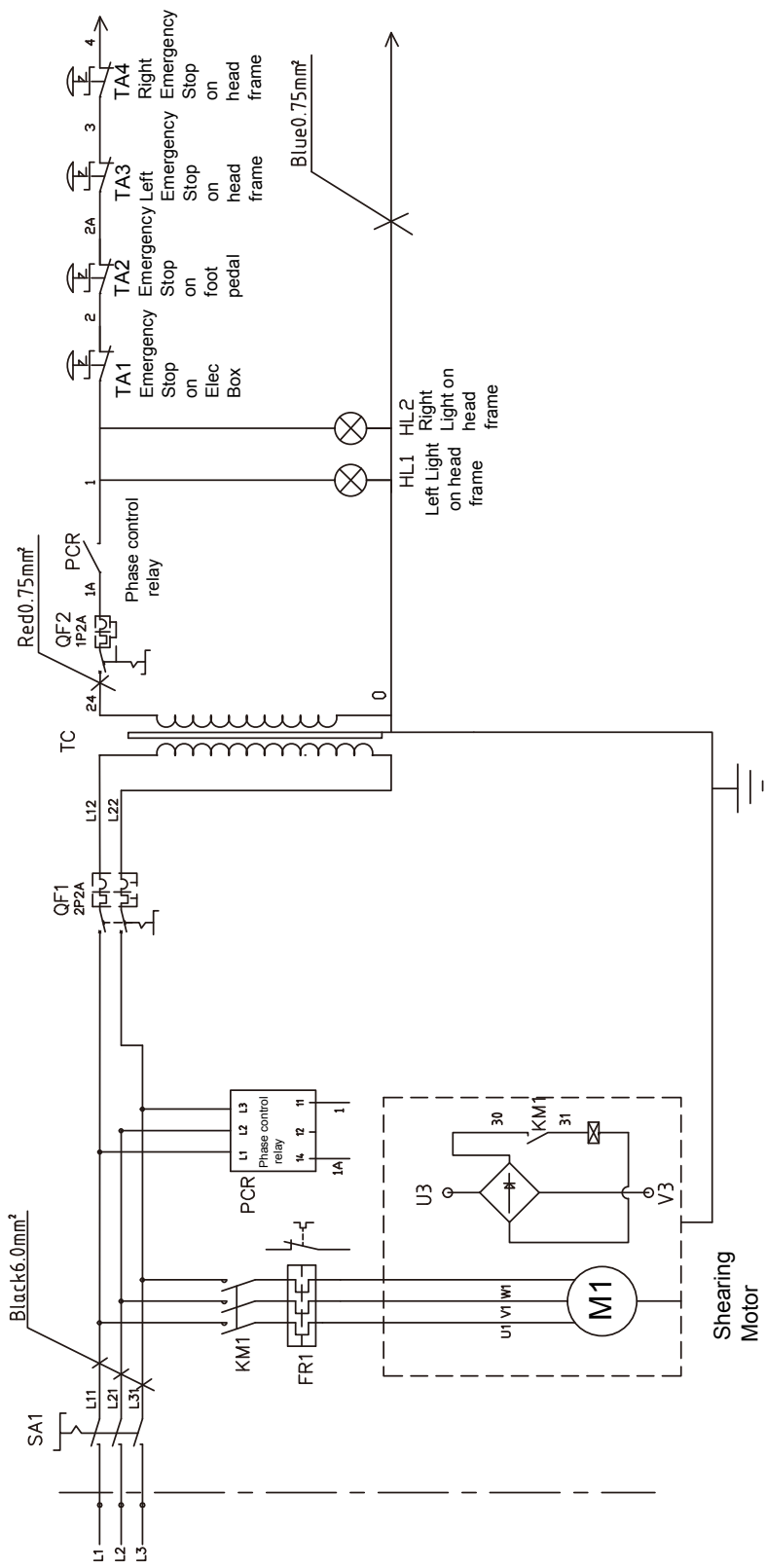

EPS-1014M /EPS-0412M/EPS-0410M/EPS-0610M

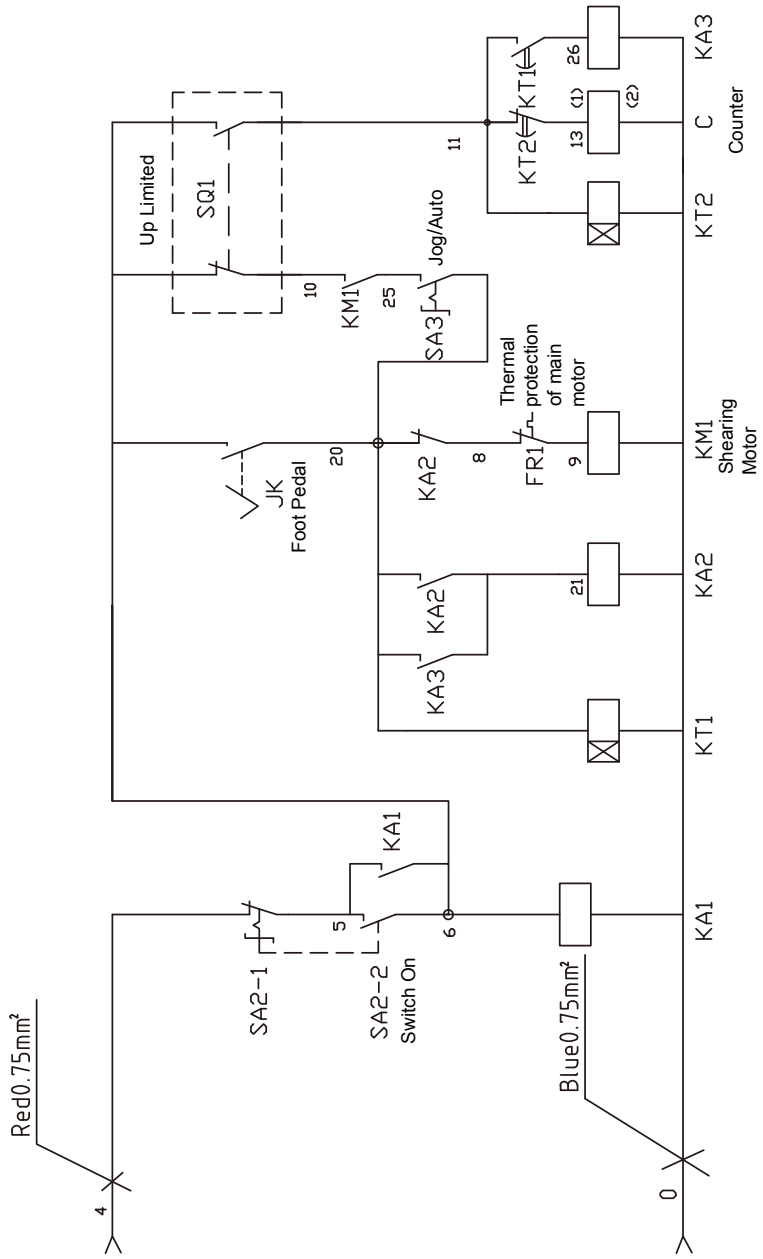

EPS-1014M /EPS-0412M/EPS-0410M/EPS-0610M

9. Parts breakdown

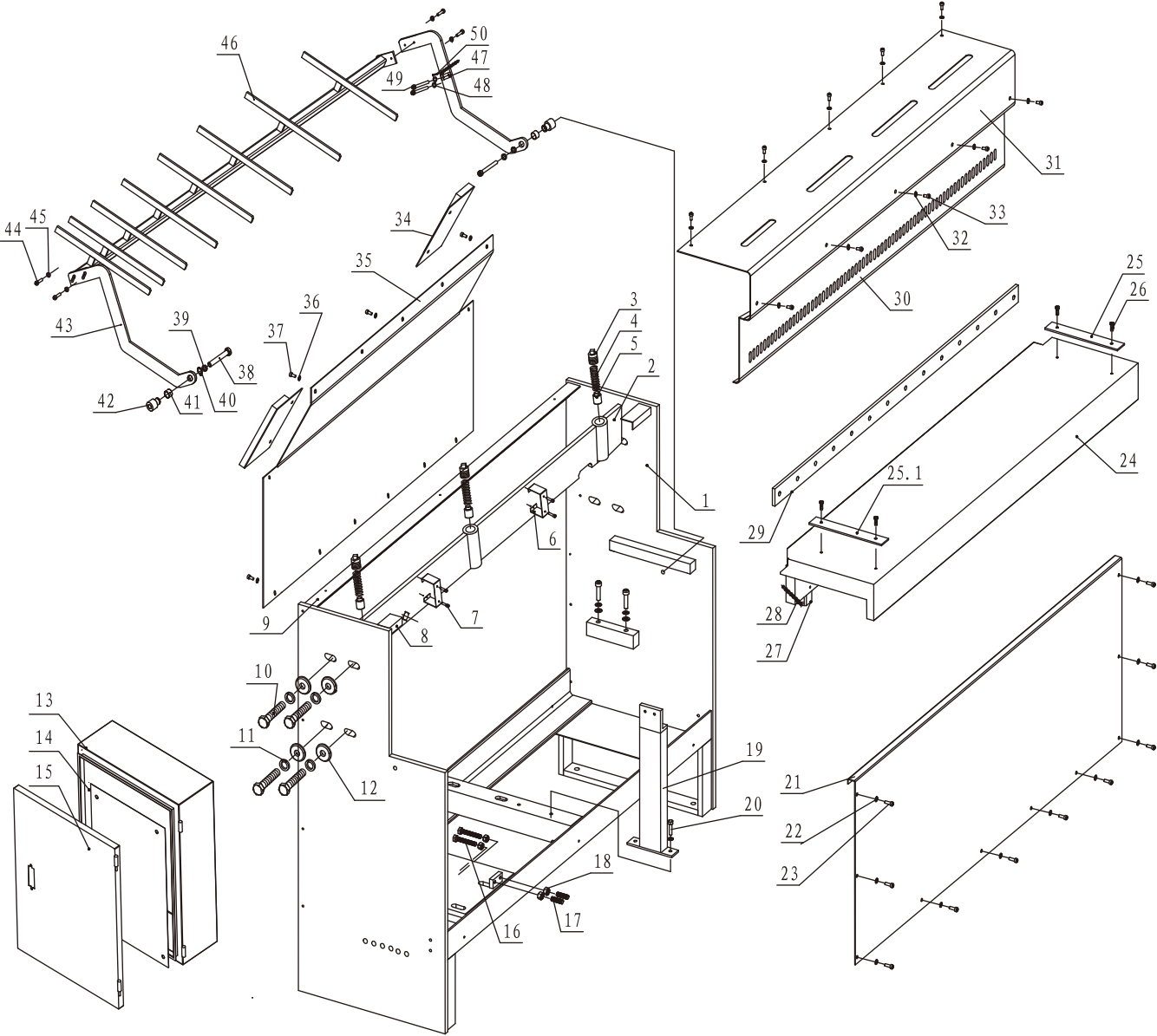

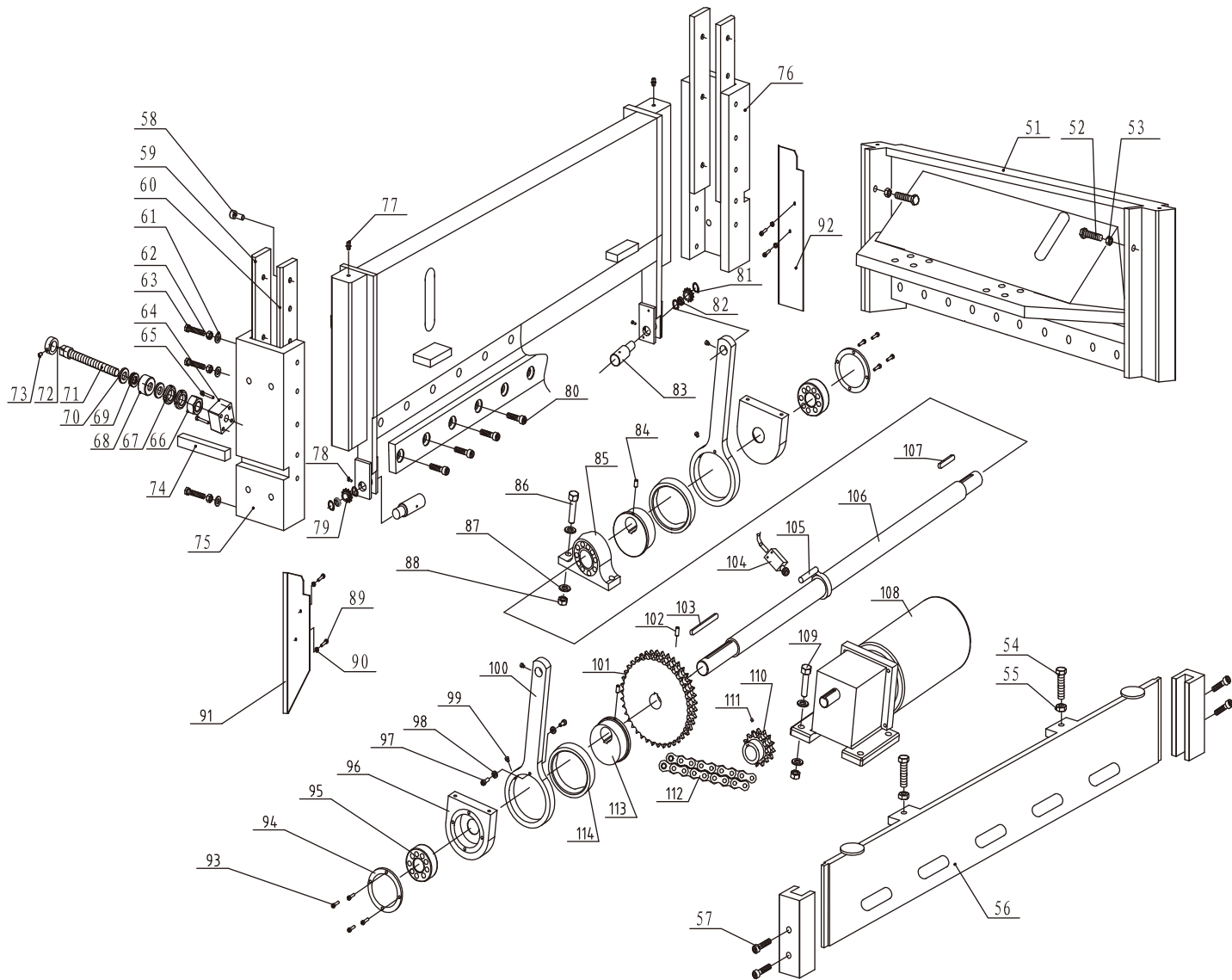

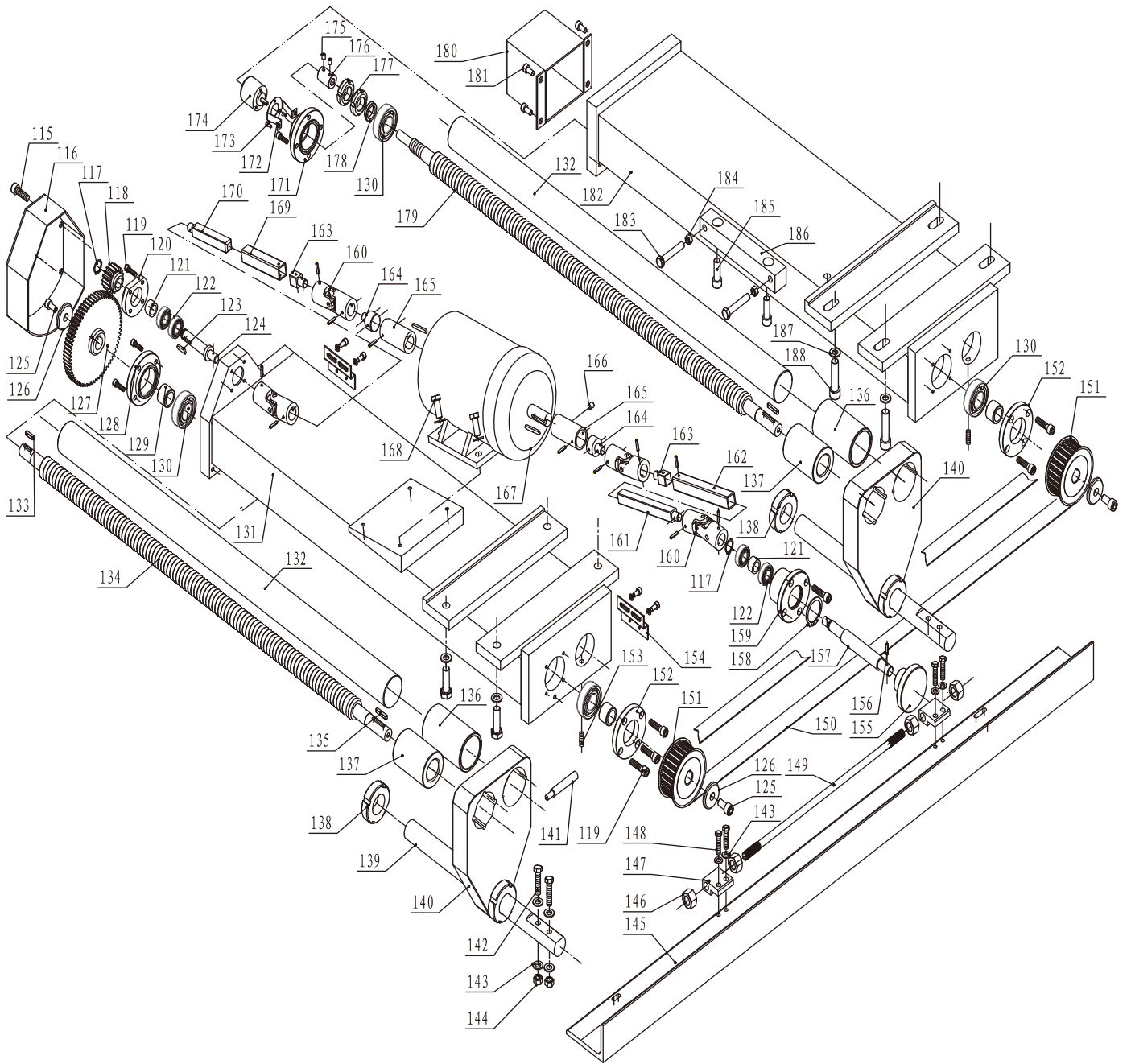

Part #	Desc.	Q'ty	Note
1	Body	1	
2	Connecting Beam	1	
3	Stud	3	
4	Pressure spring	3	
5	Shaft	3	
6	Bracket	4	
7	Bolt M6X12	16	
8	Forward support angle steel	2	
9	Upper and rear connection beam	1	
10	Bolt M16X70	8	
11	Spring Washer 16	8	
12	Washer	8	
13	Elec Box	1	
14	Cushion plate	1	
15	Electric box door	1	
16	Bolt M10X50	2	
17	Flat end tightening screwM10X30	2	
18	Nut M10	4	
19	Support frame	1	
20	Bolt M12X25	2	
21	Front Plate	1	
22	Washer 6	10	
23	Bolt M6X12	10	
24	Working Table	1	
25	Right Scale	1	
25.1	Left Scale	1	
26	Bolt M18X16	4	
27	Fixed Seat	2	
28	Chain 06B (35 Section)	2	
29	Shearing blade	2	
30	Front Cover	1	
31	Up Cover	1	
32	Plat Washer 6	10	
33	Bolt M6X12	10	
34	Brush	2	
35	Back Cover	1	
36	Flat Cover 6	12	
37	Bolt M6X12	12	
38	Bolt M12X55	2	
39	Flat Washer 12	2	
40	Shaft Ring 17	2	
41	Sleeve	2	
42	Fixed Shaft	2	
43	Supporting Rod	2	
44	Bolt M6X25	4	
45	Flat Washer 6	4	
46	Back Support Frame	1	
47	Chain Fixed Seat	2	

48	Flat Washer 8	4	
49	Bolt M8X65	4	
50	Shaft PinΦ3X26	4	
51	Upper Beam	1	
52	Copper Bolt M12X70	2	
53	Copper Nut M12	2	
54	Bolt M16X70	2	
55	Nut M16	2	
56	Pressure Beam	1	
57	Bolt M12X30	4	
58	Bolt M12X35	8	
59	Back Plate	2	
60	Front Plate	2	
61	Flat Washer 12	8	
62	Nut M12	8	
63	Bolt M12X60	8	
64	Nut Seat	2	
65	Bolt M8X45	8	
66	Nut M20X1.5	2	
67	Nut M20X1.5	4	
68	Bearing Seat	2	
69	Thrust ball bearing 53204U	2	
70	Rubbing pad	2	
71	Lead screw	2	
72	Scale Ring	2	
73	Bolt M6X8	2	
74	Guide Key	2	
75	Left Guide Groove	1	
76	Right Guide Groove	1	
77	Oil Cup M10X1	2	
78	Bolt M6X20	2	
79	Small Chain Wheel	2	
80	Bolt M10X20	32	
81	Ring 35	4	
82	Bearing 6003	2	
83	Pin	2	
84	Bolt M8X10	2	
85	Bearing UCP215	1	
86	Bolt M20X70	2	
87	Flat Washer 20	4	
88	Nut M20	2	
89	Bolt M6X12	2	
90	Flat Washer 6	2	
91	Left Cover Plate	1	
92	Right Cover Plate	1	
93	Bolt M6X16	8	
94	Cover	2	
95	Bearing 22313C/W33	2	
96	Bearing Seat	2	

97	Bolt M10X16	4	
98	Flat Washer 10	4	
99	Oil Cup M8X1	4	
100	Rocker Arm	2	
101	Big Chain Wheel	1	
102	Bolt M12X20	1	
103	Flat Key 18X160	1	
104	Travel Switch	1	
105	Pipe Clamp	1	
106	Main Shaft	1	
107	Flat Key 18X70	1	
108	Motor	1	
109	Bolt M16X100	4	
110	Small Chain Wheel	1	
111	Bolt M12X20	1	
112	Double row chain 16A	1	
113	Eccentric Gear	2	
114	Swing arm Sleeve	2	
115	Bolt M8X70	4	
116	Gear Cover	1	
117	Ring 15	2	
118	Small Gear	1	
119	Bolt M6X12	24	
120	Cover	1	
121	Spacer	2	
122	Bearing 6202-2Z	4	
123	Flat Key 5X20	1	
124	Shaft	1	
125	Bolt M8X16	3	
126	Pressure Pad	3	
127	Big Gear	1	
128	Bearing Cover	1	
129	Spacer	3	
130	Bearing 6304-2Z	2	
131	Support Frame	1	
132	Guide Shaft	2	
133	Flat Key 6X20	1	
134	Lead Screw	1	
135	Flat Key 6X32	2	
136	Sleeve	2	
137	Nut	2	
138	Round Nut M30X1.5	4	
139	Adjust Rod	2	
140	Connecting Plate	2	
141	Stroke switch shaft	1	
142	Bolt M8X55	4	
143	Washer 8	12	
144	Nut M8	4	
145	Baffle plate	1	

146	Nut M12	4	
147	Fixed Block		
148	Bolt M8X20	4	
149	Adjust Rod		
150	Synchronous Belt 3360-5M-30	1	
151	Synchronous Pulley	2	
152	Bearing Cover	3	
153	Bolt M10X20	4	
154	Travel Switch Bracket	2	
155	Handle	1	
156	Spring Pin 4X35	1	
157	Shaft	1	
158	Ring35	2	
159	Fixing Sleeve	1	
160	coupling	4	
161	Square axis	1	
162	Square Tube	1	
163	Joint	2	
164	Connecting Shaft	2	
165	Connecting Sleeve	2	
166	Bolt M5X8	2	
167	Motor for Back Gauge	1	
168	Bolt M8X35	4	
169	Square Tube	1	
170	Square axis	1	
171	bearing cover	1	
172	Bracket for Encoder	1	
173	Bolt M4X6	2	
174	Encoder	1	
175	Bolt M4X6	2	
176	Elastic tube coupling	1	
177	Round Nut M20X1.5	2	
178	Spacer	1	
179	Lead screw	1	
180	Cover of Encoder	1	
181	Bolt M8X16	4	
182	Support Frame	1	
183	Bolt M12X80	2	
184	Nut M12	2	
185	Bolt M12X35	2	
186	Fixed Plate	1	
187	Washer 12	4	
188	Bolt M12X40	4	

RED RIVER MACHINERY
1-800-729-0759
<https://www.redrivermachinery.com/>